

# Holley Carburetor Model 2300-C Instruction Sheet 199R8338

## TYPICAL VIEW

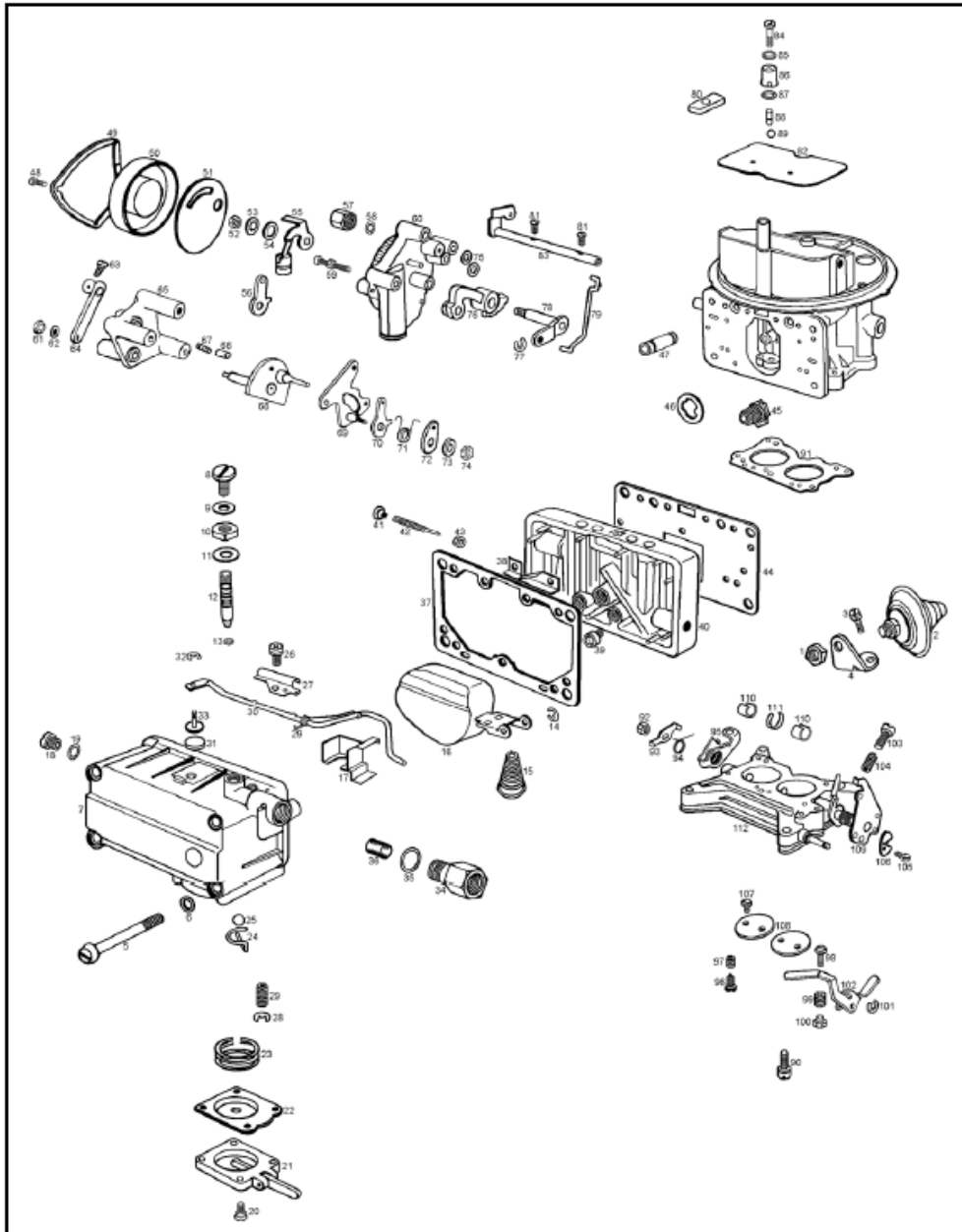
The exploded view shown is typical of the model carburetor this kit will service. The view may differ slightly from the actual carburetor being renewed.

This kit may contain more parts than are actually required to service a given carburetor. When similar gaskets or parts are included in the kit, compare with the original parts.

### DISASSEMBLY:

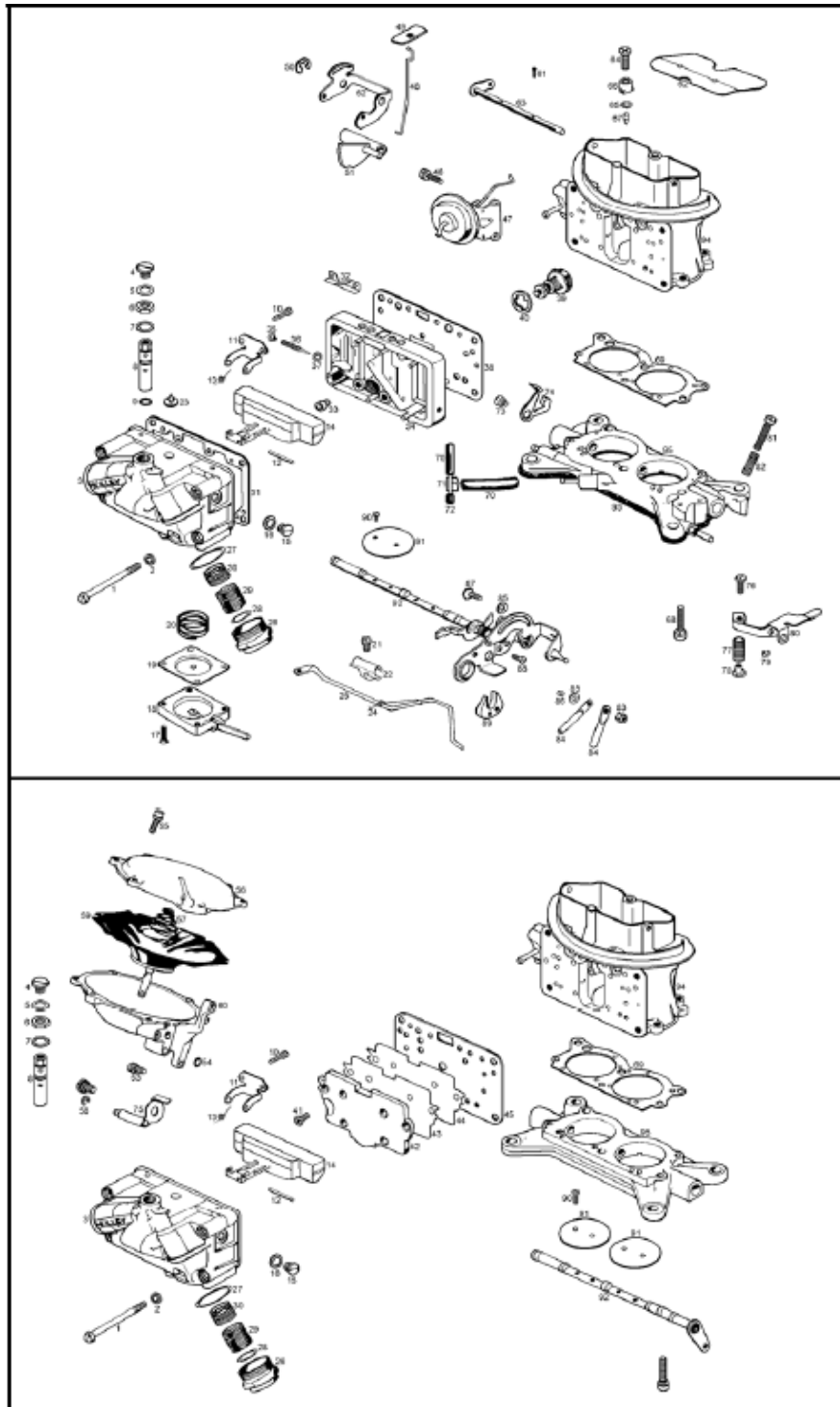
Rest the carburetor on a repair stand to avoid damage to the throttle plates during the renew procedures. Use the exploded view as a guide, and follow the numerical sequence in general to disassemble the unit far enough to permit cleaning and inspection. Do not remove the throttle plates or shaft. Idle limiter: turn the idle limiter caps to its leanest position and remove the cap. Observe and record the initial position of the needle slot. Turn the idle needs until lightly seated, recording the number of turns required to seat the needles. This procedure is necessary to reinstall the idle needles after renewing.

Use care not to damage the idle adjusting needles when removing the idle limiter caps.



Ref. No.	Description	Ref. No.	Description
1	Dashpot Locknut	2	Dashpot Assembly
3	Dashpot Bracket Screw	4	Dashpot Bracket
5	Fuel Bowl Screw	6	Bowl Screw Gasket
7	Fuel Bowl Assembly	8	Fuel Valve Seat Lockscrew
9	Lockscrew Gasket	10	Fuel Valve Seat Adjustment Nut
11	Adjustment Nut Gasket	12	Fuel Valve Assembly
13	Fuel Valve O-Ring Seal	14	Float Retainer
15	Float Spring	16	Float Assembly
17	Fuel Inlet Baffle	18	Fuel Inlet Check Plug
19	Check Plug Gasket	20	Accelerator Pump Cover Screw
21	Accelerator Pump Cover	22	Pump Diaphragm
23	Diaphragm Return Spring	24	Check Ball Retainer
25	Check Ball	26	Vent Rod Clamp Screw
27	Vent Rod Clamp	28	Vent Rod Spring Retainer
29	Vent Rod Spring	30	Vent Rod
31	Vent Cap	32	Vent Valve Retainer
33	Vent Valve	34	Fuel Inlet Fitting
35	Inlet Fitting Gasket	36	Inlet Filter Screen
37	Fuel Bowl Gasket	38	Metering Body Vent Baffle
39	Main Metering Jet	40	metering Body
41	Idle Limiter Cap	42	Idle Needle
43	Idle Needle Seal	44	Metering Body Gasket
45	Power Valve	46	Power Valve Gasket
47	Pump Transfer Tube	48	Thermostat Housing Clamp Screw
49	Thermostat Housing Clamp	50	Thermostat Housing Assembly
51	Thermostat Housing Gasket	52	Thermostat Shaft Nut
53	Shaft Nut Lockwasher	54	Spacer
55	Choke Thermostat Lever and Assembly	56	Choke Thermostat Lever
57	Heat Tube Nut	58	Heat Tube Screen
59	Choke Housing Screw	60	Choke Housing Assembly
61	Control Lever Nut	62	Lockwasher
63	Swivel Screw	64	Choke Lever & Swivel Assembly
65	Fast Idle Cam Plate	66	Fast Idle Cam Plunger
67	Plunger Spring	68	Fast Idle Cam & Shaft Assembly
69	Back-up Plate & Stud Assembly	70	Choke Rod Lever & Bushing Assembly
71	Choke Spring	72	Spring Washer
73	Back-up Plate Stud Nut Lockwasher	74	Stud Nut
75	Choke Housing Gasket	76	Fast Idle Cam
77	Choke Link Retainer	78	Choke Housing Shaft & Lever
79	Choke Link	80	Choke Link Seal
81	Choke Plate Screw	82	Choke Plate
83	Choke Shaft and Lever	84	Pump Discharge Nozzle Screw
85	Discharge Nozzle Gasket	86	Pump Discharge Nozzle
87	Discharge Nozzle Gasket	88	Pump Discharge Weight
89	Pump Discharge Ball	90	Throttle Body to Main Body Screw
91	Throttle Body Gasket	92	Fast Idle Cam Lever Screw
93	Fast Idle Pick-up Lever	94	Fast Idle Cam Lever Spring
95	Fast Idle Cam Lever	96	Fast Idle Cam Lever Screw
97	Lever Screw Spring	98	Pump Operating Lever Adjustment Screw
99	Adjustment Screw Spring	100	Adjustment Screw Nut
101	Pump Operating Lever Retainer	102	Pump Operating Lever
103	Throttle Stop Screw	104	Stop Screw Spring
105	Pump Cam Lock Screw	106	Pump Cam
107	Throttle Plate Screw	108	Throttle Plate
109	Throttle Shaft & Lever	110	Throttle Shaft Bearing
111	Throttle Shaft Bearing - Center	112	Flange Gasket

TYPICAL VIEW MODEL 2300 – 3 X 2 BBL



Ref. No.	Description	Ref. No.	Description
1	Fuel Bowl Screw	2	Bowl Screw Gasket
3	Fuel Bowl Assembly	4	Fuel Valve Seat Lock Screw
5	Lock Screw Gasket	6	Fuel Valve Seat Adjustment Nut
7	Adjustment Nut Gasket	8	Fuel Valve Assembly
9	Fuel Valve O-Ring Seal	10	Float Shaft Retainer Screw
11	Float Shaft Retainer	12	Float Lever Shaft
13	Float Spring	14	Float Assembly
15	Fuel Level Check Plug	16	Check Plug Gasket
17	Accelerator Pump Cover Screw	18	Accelerator Pump Cover
19	Accelerator Pump Diaphragm	20	Diaphragm Return Spring
21	Vent Rod Clamp Screw	22	Vent Rod Clamp
23	Vent Valve	24	Vent Rod Spring
25	Vent Rod	26	Fuel Inlet Fitting
27	Inlet Fitting Gasket	28	Fuel Filter Gasket
29	Fuel Filter	30	Fuel Filter Spring
31	Fuel Bowl Gasket	32	Metering Body Vent Baffle
33	Main Metering Jet	34	Metering Body
35	Idle Limiter Cap	36	Idle Needle
37	Idle Needle Seal	38	Metering Body Gasket
39	Power Valve	40	Power Valve Gasket
41	Metering Body Screw	42	Metering Body - Secondary
43	Metering Body Plate Gasket	44	Metering Body Plate
45	Metering Body Gasket	46	Choke Diaphragm Bracket Screw
47	Choke Diaphragm Assembly	48	Choke Rod
49	Choke Rod Seal	50	Choke Control Lever Retainer
51	Fast Idle Cam	52	Choke Control Lever
53	Diaphragm Mounting Screw	54	Diaphragm Housing Gasket
55	Diaphragm Assembly Cover Screw	56	Diaphragm Housing Cover
57	Diaphragm Spring	58	Diaphragm Link Retainer
59	Diaphragm Assembly	60	Diaphragm Housing
61	Choke Plate Screw	62	Choke Plate
63	Choke Shaft & Lever Assembly	64	Pump Discharge Nozzle Screw
65	Pump Discharge Screw Gasket	66	Pump Discharge Nozzle
67	Pump Discharge Needle Valve	68	Throttle Body to Main Body Screw
69	Throttle Body Gasket	70	Choke Diaphragm Hose
71	Tee Fitting	72	Plug
73	Fast Idle Cam Lever Screw	74	Fast Idle Cam Lever
75	Diaphragm Lever & Pin Assembly	76	Pump Operating Lever Adjustment Screw
77	Adjustment Screw Spring	78	Adjustment Screw Nut
79	Pump Operating Lever Retainer	80	Pump Operating Lever
81	Throttle Stop Screw	82	Stop Screw Spring
83	Throttle Connector Pin Nut	84	Throttle Connector Bar
85	Throttle Connector Pin Spacer	86	Throttle Connector Pin Bushing
87	Throttle Connector Pin	88	Pump Cam Lockscrew
89	Pump Cam	90	Throttle Plate Screw
91	Throttle Plate	92	Throttle Shaft & Lever Assembly
93	Flange Gasket	94	Main Body
95	Throttle Body		

#### CLEANING:

Cleaning must be done with the carburetor disassembled. Soak parts long enough to soften and remove all foreign material. Use a carburetor solvent, lacquer thinner, or denatured alcohol. Make certain the throttle body is free of all hard carbon deposits. Wash off in suitable solvent. Blow out all passages in castings with compressed air and check carefully to insure thorough cleaning of obscure areas.

**CAUTION: Do not soak parts containing rubber or plastic material. Serious damage could result.**

Fuel bowls, should only be exposed to carburetor cleaner long enough to permit removal of gum and varnish deposits with a brush.

#### REASSEMBLY:

Reassemble in reverse order to disassembly. Note special instructions and follow outline in making adjustments.

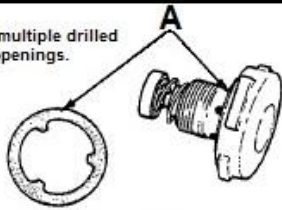
Manually operate the throttle lever and choke mechanism, checking for binding or malfunction. Any binding or interference could cause throttle to stick during operation and result in loss of carburetor throttle control (or uncontrolled engine speed).

Check carburetor to be sure there are no leaks. Flooding could cause a fire.

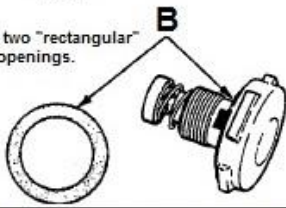
#### SPECIAL INSTRUCTIONS:

REVERSE IDLE – Some list numbers of this model carburetor use a reverse idle system and decal directions should be followed to properly set the idle mixture.

With multiple drilled fuel openings.



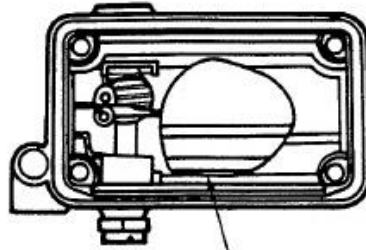
With two "rectangular" fuel openings.



**NOTE:** Proper power valve gasket must be used as shown, use of improper gasket will result in fuel leakage around power valve.  
Power valve (A): Torque to 40-50 in./lbs.  
Power valve (B): Torque to 40-50 in./lbs.

FIG. 1 - POWER VALVE INSTALLATION

1 - With fuel bowl inverted

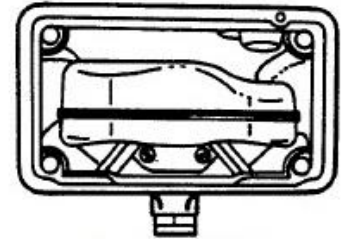


2 - Adjust float parallel to bowl floor

External Adjustable Type

FIG. 2 - DRY FLOAT SETTING

1 - With fuel bowl inverted

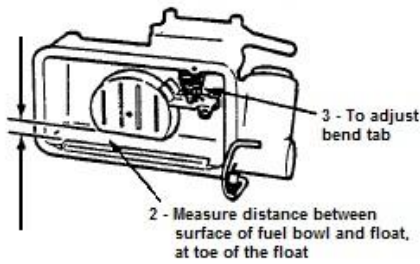


2 - Adjust float so that it is centered in the center of the fuel bowl.

Center Inlet Type

FIG. 3 - DRY FLOAT SETTING

1 - With fuel bowl inverted

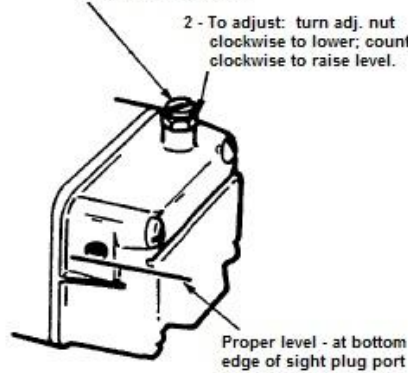


Non-Adjustable Type

FIG. 4 - DRY FLOAT SETTING

1 - Loosen lock screw

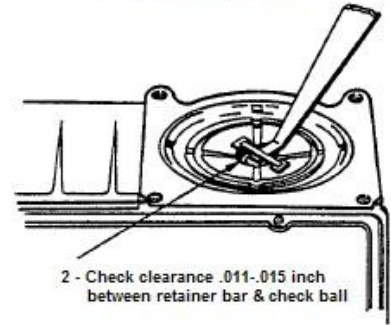
2 - To adjust: turn adj. nut clockwise to lower; counter-clockwise to raise level.



With car on level surface and engine running

FIG. 5 - WET LEVEL ADJUSTMENT

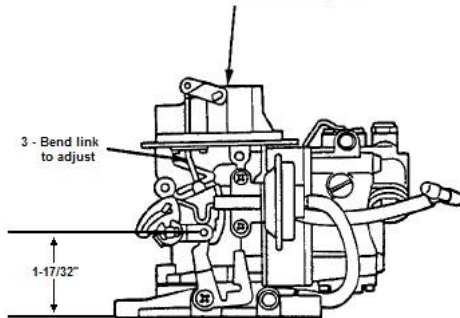
1 - With fuel bowl inverted



2 - Check clearance .011-.015 inch between retainer bar & check ball

FIG. 6 - PUMP INTAKE CHECK BALL ADJ.

1 - Close choke plate

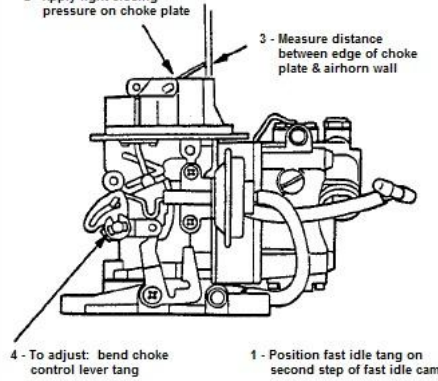


2 - Measure from top of choke rod hole to base of carburetor.

FIG. 7 - CHOKE LEVER ADJUSTMENT

2 - Apply light closing pressure on choke plate

3 - Measure distance between edge of choke plate & airhorn wall



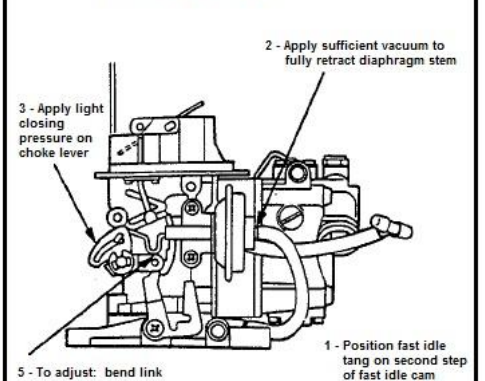
4 - To adjust: bend choke control lever tang

1 - Position fast idle tang on second step of fast idle cam

FIG. 8 - FAST IDLE CAM

4 - Measure clearance between bottom edge of choke plate & airhorn wall

2 - Apply sufficient vacuum to fully retract diaphragm stem



3 - Apply light closing pressure on choke lever

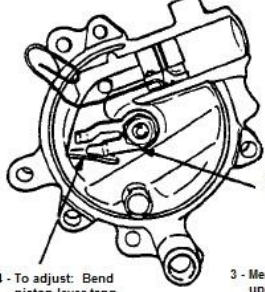
5 - To adjust: bend link

1 - Position fast idle tang on second step of fast idle cam

FIG. 9 - CHOKE QUALIFYING

NOTE: Bend a paper clip (.030 to .036 dia.) as shown to provide a hooked end no longer than 1/8 inch.

1 - Insert paper clip into piston bore until end of bore slot is hooked as shown



2 - Move piston & levers in choke closing direction until edge of piston slot engages paper clip

4 - To adjust: Bend piston lever tang.

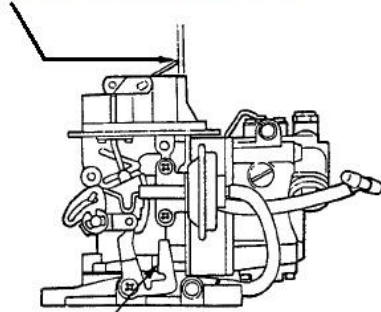
3 - Measure distance between upper edge of choke plate & air horn. See Fig. 9.

FIG. 10 - CHOKE QUALIFYING (Integral Choke)

1 - Hold throttle in wide open position.

2 - Apply light closing pressure to choke plate.

3 - Measure clearance between top edge & air horn wall.

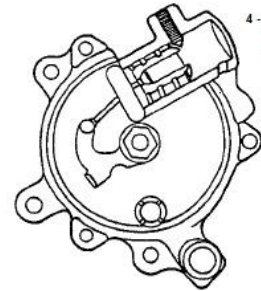


4 - To adjust: Bend tang.

FIG. 11 - CHOKE UNLOADER

1 - Push choke piston against stop.

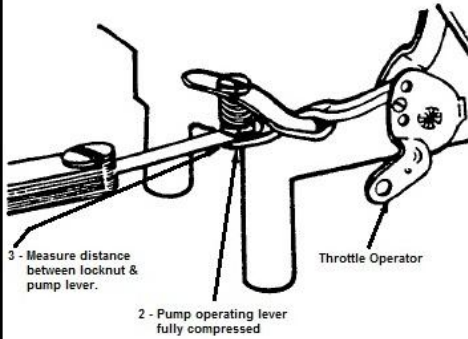
2 - Apply light closing pressure to choke plate.



4 - To adjust: turn screw in or out as required.

3 - Measure distance between upper edge of choke plate & air horn wall.

FIG. 12 - CHOKE QUALIFYING (Late Integral Choke)

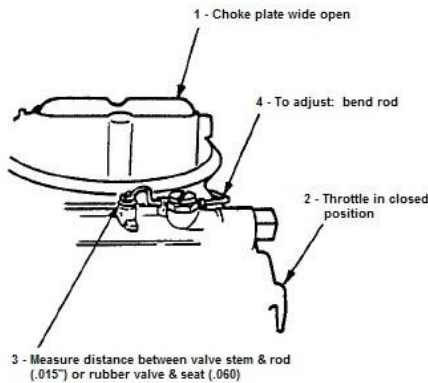


3 - Measure distance between locknut & pump lever.

2 - Pump operating lever fully compressed

Throttle Operator

FIG. 13 - PUMP OVERRIDE ADJUSTMENT



1 - Choke plate wide open

4 - To adjust: bend rod

2 - Throttle in closed position

3 - Measure distance between valve stem & rod (.015") or rubber valve & seat (.060)

FIG. 14 - VENT VALVE ADJUSTMENT

Rotate cover to align reference mark on cover with specified mark on choke housing.

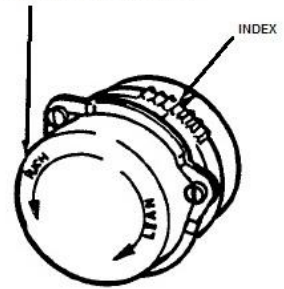


FIG. 15 - CHOKE ADJUSTMENT

1 - With choke in wide open position

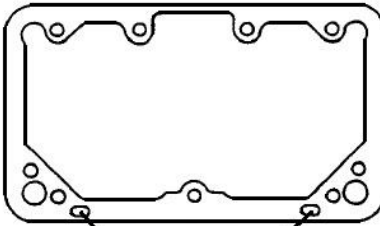
4 - Adjust to specified clearance

2 - Throttle in closed position

3 - Dashpot stem fully depressed

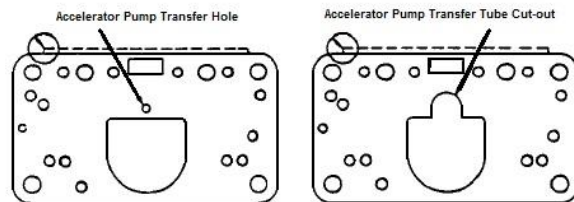


FIG. 16 - DASHPOT ADJUSTMENT



Accelerator Pump Passages

The primary fuel bowl gasket must be installed with the accelerator pump passage on the right side of the main jets. Fuel bowl screws must be torqued to 40 in./lbs.



Accelerator Pump Transfer Hole

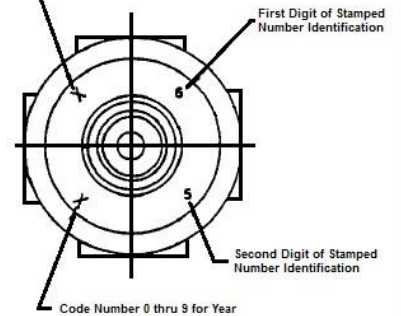
Accelerator Pump Transfer Tube Cut-out

METERING BODY GASKETS

Example: Power Valve Assembly  
125-65

65 which designates the stamped number, also identifies the opening point of the power valve (i.e., 6.5" vacuum).

Code Letter A thru M for Month - omitting Letter I - Use J for Sept.



First Digit of Stamped Number Identification

Second Digit of Stamped Number Identification

Code Number 0 thru 9 for Year

POWER VALVE IDENTIFICATION