



## OPERATING INSTRUCTIONS

### SPRING STEEL PUNCH:

1. Place punch on a HARD flat surface i.e. concrete or steel anvil. Not suitable for use on workbenches or vice clamped.
2. Insert spring steel into slot located in the front of punch until steel contacts stop.
3. Strike mandrel lightly with a hammer to punch hole.  
**Excessive force may damage mandrel or punch.**
4. Periodically remove the punch from the block and apply a coat of grease to the body of the punch.

Strike mandrel lightly with a hammer to punch hole

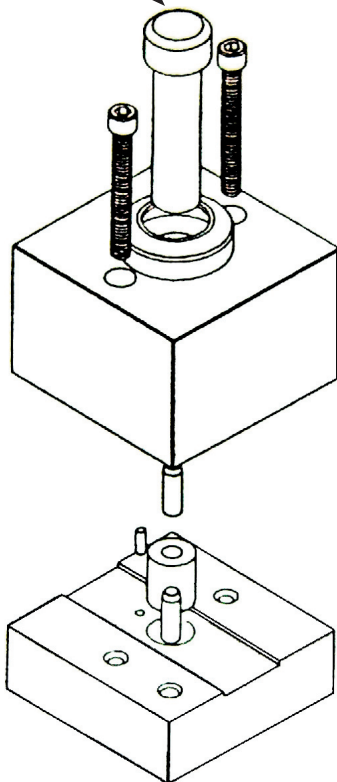

Always wear safety glasses when using punch

Allstar Performance  
8300 Lane Dr., Watervliet, MI 49098  
Phone: (269) 463-8000 Fax: (800) 772-2618  
[www.allstarperformance.com](http://www.allstarperformance.com)



## OPERATING INSTRUCTIONS

### SPRING STEEL PUNCH:

1. Place punch on a HARD flat surface i.e. concrete or steel anvil. Not suitable for use on workbenches or vice clamped.
2. Insert spring steel into slot located in the front of punch until steel contacts stop.
3. Strike mandrel lightly with a hammer to punch hole.  
**Excessive force may damage mandrel or punch.**
4. Periodically remove the punch from the block and apply a coat of grease to the body of the punch.

Strike mandrel lightly with a hammer to punch hole

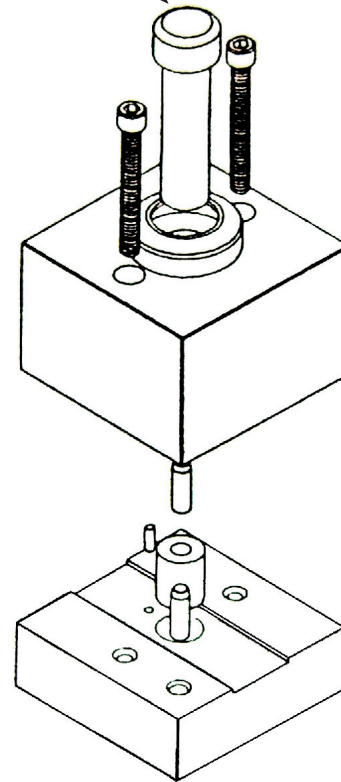

Always wear safety glasses when using punch

Allstar Performance  
8300 Lane Dr., Watervliet, MI 49098  
Phone: (269) 463-8000 Fax: (800) 772-2618  
[www.allstarperformance.com](http://www.allstarperformance.com)